

VERTICOT

OPERATING INSTRUCTIONS



SMPR CONTROLE

Les Essarts

F-76530 GRAND COURONNE

☎: +33 (0) 2 35 67 26 80

Fax : +33 (0) 2 35 67 01 64

e-mail : contact@smpr.com

Web : www.smpr.com

FOREWORD

**READ THE SAFETY RULES OF THE APPENDIX B VERY CAREFULLY BEFORE
USING THE DEVICE**

WARNING

The information contained in this booklet can be changed without notice.

The manufacturer makes no warranty whatsoever with respect to warranties of commercial quality of this product or its suitability to a particular use.

The manufacturer is not responsible for mistakes that could be found in this handbook and also for direct or indirect damage resulting from the equipment, its performances and the use of this product.

CLEANING

Use a soft cotton cloth slightly soaked with an ethyl alcohol based product.

DO NOT USE the following products: acetone, benzene, toluene and halogens hydrocarbons.

<u>FOREWORD</u>	2
<u>1. INTRODUCTION</u>	4
<u>1.1. PRESENTATION OF THE PRODUCT</u>	4
<u>1.2. TECHNICAL SPECIFICATIONS</u>	4
<u>1.3. THE FRONT PANEL</u>	5
<u>1.4. THE BACK PANEL</u>	6
<u>1.4.1. THE COMMUNICATION PORT</u>	7
<u>1.4.2. ORBIT BUS FOR DIGITAL PROBES</u>	7
<u>2. SIMPLIFIED STARTING OPERATION</u>	8
<u>2.1. PROBE COMBINATION</u>	8
<u>2.2. TOLERANCE LIMITS</u>	9
<u>2.3. DISPLAY AND ADJUSTMENT OF PROBES</u>	9
<u>2.4. DEFINITION OF THE MASTER DIMENSION AND CALIBRATION</u>	9
<u>3. ADVANCED FUNCTIONS</u>	10
<u>3.1. SELECTION OF CALIBRATION MODES</u>	10
<u>3.2. CALIBRATION TOLERANCE</u>	10
<u>3.3. SELECTION OF THE MEASURING MODE</u>	10
<u>3.4. RELATIVE DISPLAY</u>	11
<u>3.5. LIMITATION OF PROBE MEASURING RANGES</u>	11
<u>3.6. SPEED SELECTION OF THE COMMUNICATION PORT</u>	11
<u>3.7. REMOTE CONTROL OF RELATIVE DISPLAY OR CALIBRATION</u>	12
<u>3.8. DISPLAY SCALES</u>	12
<u>3.9. PROBE INPUT CONFIGURATION</u>	12
<u>3.10. HOW THE INDICATOR LIGHTS WORK</u>	13
<u>3.11. PROGRAMMING 0-10 VOLTS AND 4-20 MA OUTPUTS</u>	13
<u>3.12. PROGRAMMING THE SORTING OPERATION</u>	13
<u>3.13. TEMPORARY CHANGE OF MEASURING MODE</u>	14
<u>3.14. STARTING OF DYNAMIC MEASUREMENT</u>	14
<u>3.15. MEASUREMENT STOP</u>	14
<u>3.16. MEASURING WITH SEVERAL TYPES OF PARTS</u>	14
<u>3.17. AUTOMATIC CHANGE OF CHARACTERISTIC</u>	14
<u>3.18. STORING THE CHARACTERISTIC NUMBER</u>	15
<u>3.19. CALCULATION OF AVERAGES</u>	15
<u>3.20. ADDRESS FOR MULTI-POINT COMMUNICATION</u>	15
<u>3.21. REFERENCE OF LINEAR ENCODERS</u>	15
<u>3.22. LOCKING / UNLOCKING THE KEYBOARD</u>	16
<u>3.23. GENERAL INITIALISATION</u>	16
<u>3.24. DEFAULT PARAMETERS</u>	16
<u>4. COMMUNICATION PROTOCOLS</u>	17
<u>4.1. STATUS REGISTERS</u>	17
<u>4.2. SIMPLIFIED PROTOCOL</u>	18
<u>4.3. MODBUS (OR JBUS) PROTOCOL</u>	18
<u>4.3.1. GENERALITIES</u>	18
<u>4.3.2. NUMBER OF REGISTERS</u>	19
<u>4.3.3. NUMBER OF REAL VALUES FOR THE SELECTED CHARACTERISTIC</u>	19
<u>4.3.4. READING REQUESTS</u>	20
<u>4.3.5. WRITING REQUESTS</u>	20
<u>4.3.6. ERROR MESSAGES</u>	20
<u>5. EXAMPLES OF PROBE COMBINATIONS</u>	21
<u>5.1. SIMPLE MEASUREMENTS WITH ONE PROBE</u>	21
<u>5.2. COMBINED MEASUREMENTS WITH TWO PROBES</u>	21
<u>5.3. MEASUREMENTS WITH THREE PROBES</u>	22
<u>5.4. MEASUREMENTS WITH FOUR PROBES</u>	23
<u>6. INPUTS / OUTPUTS</u>	24
<u>6.1. RELAY BOARD REF. 24130</u>	24
<u>6.2. MULTI-FUNCTIONAL BOARD REF 24140</u>	26
<u>7. ERROR MESSAGES</u>	28
<u>8. APPENDIXES</u>	29
<u>8.1. APPENDIX A</u>	29
<u>8.2. APPENDIX B</u>	30

1. INTRODUCTION

1.1. PRESENTATION OF THE PRODUCT

The electronic comparator **Verticot** enables to check dimensions from inductive and digital probes or linear encoders.

It is possible to make simple measurements (with one probe), measurements of sums or differences (with 2 to 4 probes).

The measured values are compared with a reference piece : the master.

A comparator operated by a microprocessor

The electronic comparator **Verticot** operated by a microprocessor is fully programmable thanks to its keyboard. So it can be used in many different configurations.

1.2. TECHNICAL SPECIFICATIONS

- 2 inputs for inductive probes, extensible to 4 (sensitivity 73,75 mV/V/mm on 2 kOhms)
- Orbit bus (RS485) for digital probes or linear encoders, maximum 4
- 8 control configurations or characteristics (tolerances, nominal value, etc..) can be selected by means of the keyboard, by the protocol ModBus or by external command (only 1 to 4)
- Automatic change of characteristic upon detection of probe moving
- Static and dynamic dimensions
- Simultaneous display of the dimension and the tolerances by a bargraph display completed with a numerical display
- Over/under tolerance limit warning lights
- RS232 or RS485 communication port for the connection to a PLC or a computer
- 4 key alphanumeric tactile keyboard
- Working temperature: +15°C to +30°C
- Relative humidity: maximum 80%
- Dimensions: 50 mm wide, 349 mm high, 140 mm deep
- Weight: 1100 grams

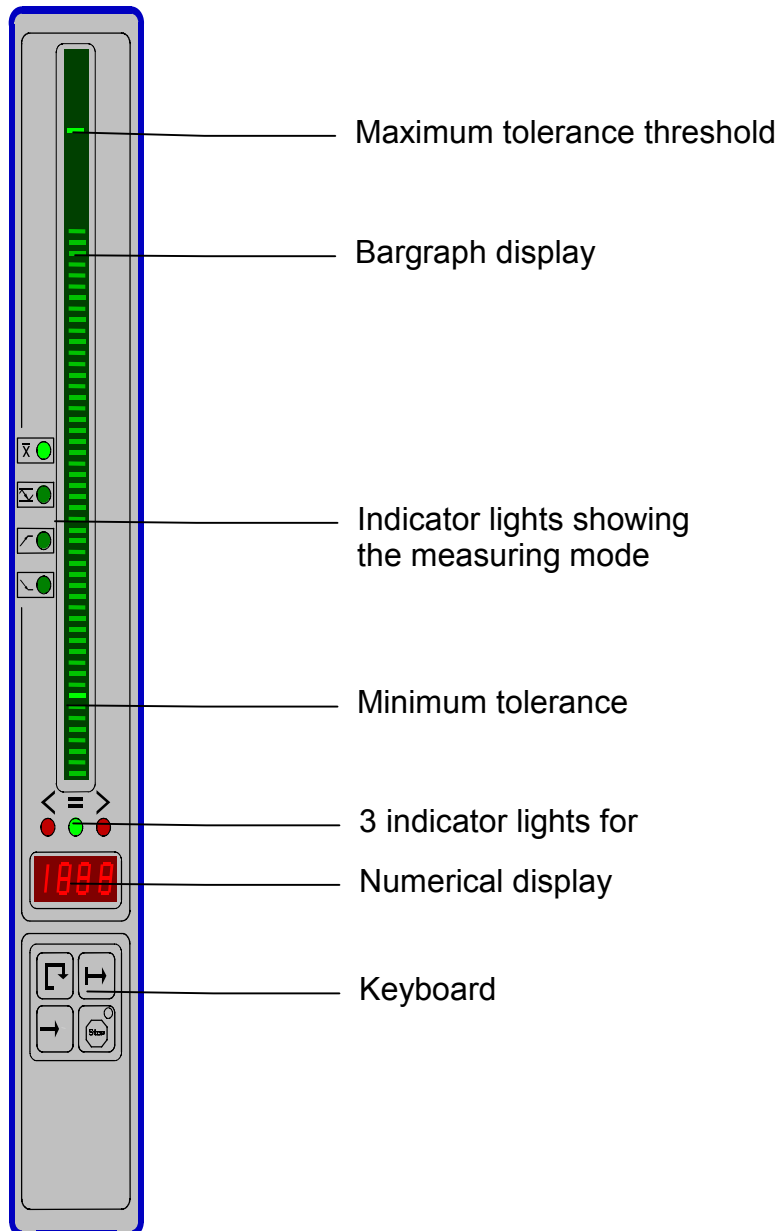
1.3. THE FRONT PANEL**Fig. 1**

1.4. THE BACK PANEL

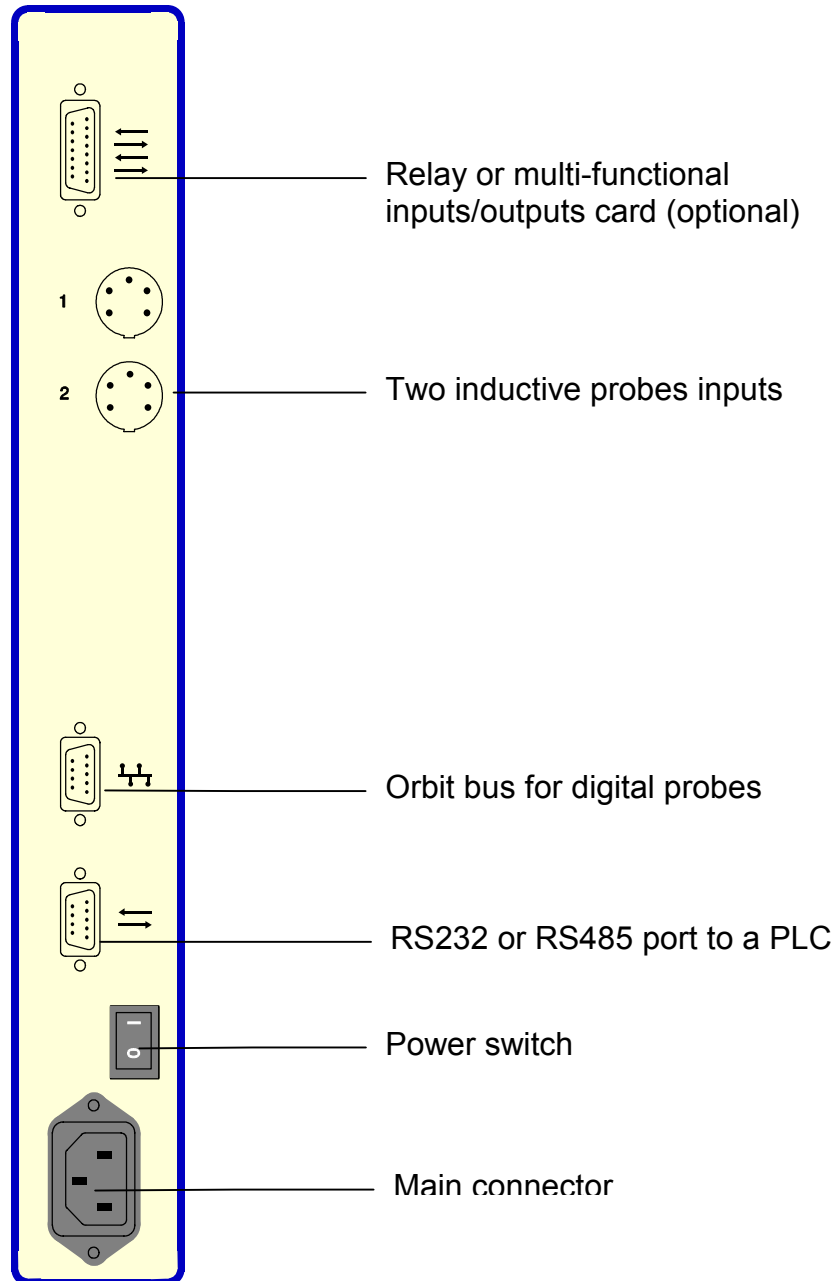

Fig. 2

1.4.1. THE COMMUNICATION PORT

The **Verticot** is fitted with a serial port, marked $\uparrow\downarrow$. It enables to connect the device to a PLC or a computer. It is used in RS232 or RS485 according to the acquired configuration.

The transmission format is as follows : 1 start bit, 8 data bits, 1 stop bit, no parity
The user can change the speed.

It is fitted with a Sub D 9 pin- female plug.

Signal description and pin assignment (RS232).

Pin	Signal	Direction	Description
1			Not used
2	RX	Input	Reception of data
3	TX	Output	Transfer of data
4			
5	Ground	-	Ground / signal return
6 to 9			Not used

Signal description and pin assignment (RS485).

Pin	Signal	Direction	Description
1,4,6,7,8,9			Not used
2	A	$\leftarrow \rightarrow$	data
3	B	$\leftarrow \rightarrow$	data
5	0V Ground		Ground

1.4.2. ORBIT BUS FOR DIGITAL PROBES

The **Verticot** is fitted with a RS485 bus used to connect digital probes or linear encoders.

“ DIGITAL PROBE BUS ” CONNECTOR PIN ASSIGNMENT

It is fitted with a Sub D 9 pin female connector.

Signal description and pin assignment.



<i>Pin</i>	<i>Signal</i>	<i>Direction</i>	<i>Description</i>
1,4,5,9	0V	-	Power supply for probes
2	A	$\leftarrow \rightarrow$	data
3	B	$\leftarrow \rightarrow$	data
6,7,8	+5V		Power supply for probes

2. SIMPLIFIED STARTING OPERATION



Follow the four points included in the simplified starting operation to get the Verticot working.

When it is switched on, the Verticot is in measuring mode. The measuring mode carries out the reading of probes, calculates the dimension from programmed combinations, compares the dimension with tolerances and displays the results.

You have access to all configurations and parameters or you can change them further to the principle underneath:



In measuring mode, you may have access to the mode defining parameters with the key combination  .

The Verticot then shows the message « Fn01 » to indicate the access to the first function defining parameters.

With the key , you may run the 44 functions available in increasing order. With the key , you may run them in descending order.

When the number of the function to be modified is displayed, the key  triggers the display of the selected parameter and enables to modify it.

The key  is used to select amongst the possible values.

To enter a value, please select the figure to be modified (it flashes), then modify it with the key . With the key , you may change figures.

By pressing the key  you may go back to the mode defining parameters (Fn nn).

By pressing the key  again, you go back to the measuring mode.

2.1. PROBE COMBINATION

In measuring mode, the Verticot carries out the reading of probes, calculates the dimension from programmed combinations.

The calculation formula used is the following:

$$(Fn05 * C1) + (Fn06 * C2) + (Fn07 * C3) + (Fn08 * C4)$$





C1 to C4 represent the probes 1 to 4.

Fn05 to Fn08 represent the coefficients of probes 1 to 4.

The coefficients stored in the functions Fn05 to Fn08 are **real numbers** chosen in the interval $-20 < K < +20$.

A non-used probe must be given a coefficient 0. The sign of the coefficient enables to choose the probe direction.

The coefficients Fn05 to Fn08 are displayed or changed in the following way :

The key combination   shows the message « Fn01 ». By pressing the key  four times, the message « Fn05 » is displayed. By pressing the key  the coefficient of probe 1 is displayed (with the left figure flashing).

At that time, the value can be modified if needed.

By pressing the key  twice, you go back to the mode defining parameters then to the measuring mode.

Same procedure for probes 2 to 4 with Fn06 to Fn08.

The default combination is $(1 \cdot C1) + (0 \cdot C2) + (0 \cdot C3) + (0 \cdot C4)$

2.2. TOLERANCE LIMITS

The tolerance limits shown by 2 brighter Leds on the bargraph display determine the indicator lights and relays working.

The minimum and maximum tolerances are the minimum and maximum values of the part.

The functions **Fn11** and **Fn12** enable to display or modify the minimum and maximum tolerances.

2.3. DISPLAY AND ADJUSTMENT OF PROBES

This function is used to enable to adjust the mechanical position of probes on the measuring stand. The position of probes must be adjusted nearest to zero (at half the measuring stroke).

With the function **Fn01** the direct value of probe 1 is displayed, without the calculation of the combination with other probes. If the probe is of digital type, it must be identified. If it is not, the message 'ld.x' is displayed. You must then press the tip of the probe to enable its identification. As soon as you have done it, the value of the probe is displayed.

Press the  key twice to go back to the measuring mode.

The same procedure enables the display of probes 2,3,4 with **Fn02**, **Fn03** and **Fn04**.

The key  cancels the identification of the digital probe. The message 'ld.x' is then displayed. This procedure enables a change of probe.

2.4. DEFINITION OF THE MASTER DIMENSION AND CALIBRATION

The Verticot measures by comparison with a reference piece, the master. For that, it is necessary to define the dimension of the reference piece. Then the Verticot measures this masterpiece and stores the result as reference. This operation is called the calibration.

The function **Fn44** displays the present value of the masterpiece. The new value of the masterpiece can then be entered by means of the keyboard. To stop entering values, press the  key twice.

This action triggers the reading of the masterpiece that must be present under the probe(s).





The calibration is kept permanently until the next calibration procedure.

The Verticot is now ready for operation.

3. ADVANCED FUNCTIONS

3.1. SELECTION OF CALIBRATION MODES

The Verticot allows choosing between 2 calibration modes:

- **Direct calibration.** The calibration is triggered by pressing the key combination   or by the function F44. Using the function in an inopportune way can have serious consequences, because it changes the reference of the measurement.
- **Calibration and control of repetition.** In this mode, the calibration is carried out once in the same way as for the direct calibration. Then on pressing the  and  keys on their own, you check if the dimension read on the master piece has not changed by a value bigger than the defined tolerance of repetition since the last calibration.

Selection of the calibration mode:

The function **Fn10** displays the calibration mode:



« **C0** » for direct calibration, or « **C1** » for calibration and control of repetition.

Use the  key to change modes.

3.2. CALIBRATION TOLERANCE

If the « Calibration and control of repetition mode » (C1) has been selected, a calibration tolerance must be defined. It is the maximum shift of the dimension read on the master piece that will be allowed in the different future controls of repetition, by comparison with the dimension read on the master piece during the calibration.

The function **Fn42** displays the present value of the calibration tolerance. The new value of the calibration tolerance is then entered by means of the keyboard.

Every time you then press the  and  keys, the Verticot carries out a **control of repetition**. It means that the dimension read on the masterpiece, that must be under the probe(s) is compared with that read during the calibration. If the difference between this dimension and that of the calibration exceeds the specified quantity, an error message « E 05 » is then displayed. To go back to normal working, you either need to carry out another control of repetition with a difference lower than the calibration tolerance or make another calibration (Fn44).

3.3. SELECTION OF THE MEASURING MODE

The Verticot enables to choose between 5 measurement modes:

- *Direct measurement*

The displayed value represents the measured value.

- *Minimum value*

The displayed value represents the minimum value met since the beginning of the measuring. It is a dynamic measurement.

- *Maximum value*

The displayed value represents the maximum value met since the beginning of the measuring. It is a dynamic measurement.

- *Average*

The displayed value represents the median or the average (see § 3.19) of the values met since the beginning of the measuring. It is a dynamic measurement.

- *Difference*



The displayed value represents the difference between the maximum and the minimum values met since the beginning of the measuring. It is a dynamic measurement.

When selecting this mode, the lower tolerance is set to 0 if negative.

Modification of the measuring mode:

The function **Fn09** displays the message « **Md** ». The key  enables to change modes. The selected mode is indicated thanks to 4 indicator lights. In direct mode, the 4 indicator lights are switched off.

3.4. RELATIVE DISPLAY

Pressing the  key will reset the display and the maximum and minimum memories to 0. The Verticot then displays the moves from this origin. It is a temporary function that won't be saved. It can be used as often as necessary. It remains on until you next press   again or until the device is switched off.

3.5. LIMITATION OF PROBE MEASURING RANGES

For greater working security, it is possible to limit the working range of the probes. Thus, as soon as this probe goes out of the range, an error message is immediately displayed (E 01 to E 04).

The function **Fn13** displays the present value of the maximum limit of probe 1. The new maximum limit value of probe 1 is then entered by means of the keyboard.

Press the key  to stop entering values.

The function **Fn14** displays the present value of the minimum limit of probe 1. The new minimum limit value of probe 1 is then entered by means of the keyboard.

In the same way, we can display and change the limits of the other probes by using the functions **Fn15** and **Fn16** for probe 2, the functions **Fn17** and **Fn18** for probe 3 and the functions **Fn19** and **Fn20** for probe 4.

3.6. SPEED SELECTION OF THE COMMUNICATION PORT

The Verticot is fitted with a serial port, marked "  ". It enables to connect the device to a PLC or an external system. It can be used in RS232 or in RS485 according to the acquired configuration.

The transmission format is the following: 1 start bit , 8 data bits, 1 stop bit, no parity.
The user can change the speed.

The speed is regulated between 150 and 19600 baud. To select the speed, use the function **Fn21**.

With the  key, the speed can be modified from 'b1' =150 baud to 'b8' =19200 baud according the following table:

b1 = 150 baud	b2 = 300 baud	b3 = 600 baud	b4 = 1200 baud
b5 = 2400 baud	b6 = 4800 baud	b7 = 9600 baud	b8 = 19200 baud

The Verticot is delivered with a speed set at 9600 baud ('b7').

3.7. REMOTE CONTROL OF RELATIVE DISPLAY OR CALIBRATION

As needed, input "ZERO" (see § 6.1 & 6.2) can be used in two different ways. Tanks to function **Fn22** and  it is possible to select

- 'mo 0' (default) to remote control of relative display.
- 'mo 1' to remote control of calibration. Calibration will be performed according to the selected mode (see §3.1)

3.8. DISPLAY SCALES

The function **Fn29** permits to choose between 7 measurement scales, 4 in metric units and 3 in English units (inch).

The metric scales are:

e0 = ±1.999 mm, e1 = ±19.99 mm, e2 = ±199.9 mm and e3 = ±199.9 μm

The English scales (1 mils = 1/1000 inch) are:

e4 = ±19.99 mils, e5 = ±199.9 mils and e6 = ±1999 mils.

3.9. PROBE INPUT CONFIGURATION

The Verticot allows you to use 4 probes. In its most current version, it is fitted with 2 inputs for inductive probes and a bus for digital probes or linear encoders. According to your needs, you can choose only one inductive probe, or even none. In this case, it is possible to modify the distribution between inductive probes and digital probes. This distribution can be displayed with the function **Fn24**.

The display then shows C 2 2 . The first 2 indicates the use of 2 inductive probes, the 2 to the right indicates the use of 2 digital probes. The key  enables to modify this distribution.

3.10. HOW THE INDICATOR LIGHTS WORK

If the part is out of tolerances, the corresponding indicator lights up. It is possible to store a fugitive over/under tolerance limit by using the memorisation of over/under tolerance limits. The mode in operation is displayed via the function **Fn23**.

The display then shows « L0 » (the indicator lights are not stored) or « L1 » (the indicator lights are stored).

Press the key  to go from the mode with to the mode without storage of over/under tolerance limits.

The key  clears the memory of the indicator lights.

3.11. PROGRAMMING 0-10 VOLTS AND 4-20 mA OUTPUTS

When the multi-functional board ref 24140 (see § 6.2) is installed, we have 2 analogue outputs 0 to 10 Volts and 4 to 20 mA. The dimension corresponding to the output voltage 0 Volt and to the current 4 mA is entered with the function **Fn25**, followed by the corresponding dimension.

The dimension corresponding to the output voltage 10 Volts and to the current 20 mA is entered with the function **Fn26**, followed by the corresponding dimension.

3.12. PROGRAMMING THE SORTING OPERATION

The Verticot enables to sort parts. It is possible to define up to eight classes maximum, and to display directly the number of the class corresponding to the measured dimension.

When the multi-functional card option ref. 24140 (see § 6.2) is installed, each has a corresponding output on the connector.

To use the sorting function, you first need to define the number of classes you want with the function **Fn30**, then the key  that increases by 0 (no class), then from 1 to 8 classes.

Then the limits of each class have to be defined with the following functions.

Fn31 : mini threshold of class 1. **Fn32** : mini threshold of class 2



Fn33 : mini threshold of class 3. **Fn34** : mini threshold of class 4

Fn35 : mini threshold of class 5. **Fn36** : mini threshold of class 6

Fn37 : mini threshold of class 7. **Fn38** : mini threshold of class 8



The function **Fn39** determines the upper limit of class 8.

Note: You don't have to enter all thresholds. If you only use 4 classes, you will only enter 5 values (the 4 mini thresholds of the first 4 classes and the maxi of the fourth class which is the mini threshold of class 5).

With the keys   you may go from the dimension display (standard) to the active class display « C n » (n is the class number). When the measured dimension is outside the class limits, the display then shows « C 0 ».

3.13. TEMPORARY CHANGE OF MEASURING MODE

This change enables to view all the information about the measured dimension (direct dimension, maxi, mini, average, difference). It is only for the numerical display. The tolerances always depend on the default mode.

In measuring mode, you may go from one mode to the other with the key . If you press the key  or if you do not touch the keyboard during 25 seconds, the display goes back to the default mode.

3.14. STARTING OF DYNAMIC MEASUREMENT

By pressing the key  the maximum and minimum memories used to measure the shape faults are reset to 0. The key must be pressed when the part is already adjusted under the probes not to record the erroneous data.

3.15. MEASUREMENT STOP

Pressing the key  will stop the measurements such as the display. A red indicator light confirms the measurement stop. Pressing this key again will start them again. It is therefore possible to block the display on a value, to stop a static or dynamic measurement temporarily or permanently.



3.16. MEASURING WITH SEVERAL TYPES OF PARTS

The Verticot has a memory that can contain 8 data sets corresponding to 8 different characteristics. It is possible to select active data by a command entered by means of the keyboard, by an external command (only for 1 to 4) or by communication port. When switching-on, the message 'P.n' indicates the selected characteristic 'n'.

The function **Fn43** enables to select the data sets from 1 to 8.

3.17. AUTOMATIC CHANGE OF CHARACTERISTIC



When it detects a probe movement, the Verticot automatically moves to the corresponding characteristic. Every probe movement of at least 20 µm will select the characteristic to which the probe belongs (with display of 'P.n' : n = characteristic nr). In this mode, if a probe is validated in several characteristics, only the first one will be activated when this probe will move. Two different probes can activate the same characteristic.

The function **Fn41** allows, with the -key, to display 'oC 1' to activate the automatic change, or 'oC 0' to inhibit it. If the automatic change is not activated, the -key will then display 'oC 0x' : see § 3.18.

3.18. STORING THE CHARACTERISTIC NUMBER

The number of the characteristic can be stored; when switching on, the Verticot will then start with the last characteristic used.

In case of frequent characteristic change (by means of the keyboard and particularly by external commands), we suggest suppressing the storing of the characteristic number; this will avoid reducing the life of the storing memory. In case of automatic change of characteristic (see § 3.17), the automatic storing is suppressed.

If the automatic change of characteristic is not activated, the function **Fn41** will display 'oC 0', then valid with the -key, the display will indicate 'oC 00' to quit the storing or 'oC 01' to select it: choice with the -key.

3.19. CALCULATION OF AVERAGES

The Verticot allows choosing between two methods to measure an average dimension:

- An average value calculated by adding all the readings made at regular intervals, divided by the number of measured values. This method requires a regular move of the part under the probe, as well as precise starts and stops of measurement.
- A median value calculated by doing the average of the maximum and minimum values met during the measurement.

The mode in operation is displayed with the function **Fn27**. The display indicates « M 1 » for the calculation of the median (default), « M 0 » for the calculation of the average. To go from one to the other use the key .

3.20. ADDRESS FOR MULTI-POINT COMMUNICATION

The device can communicate through the communication port, either through a specific protocol Metro (in ASCII), or through the ModBus/JBus protocol (binary).

The **number 0** selects the specific protocol Metro (configuration of origin).

A device number between 1 and 247 selects the ModBus/JBus protocol.

The number is displayed with the function **Fn28**. You can then increase or decrease the number, by step of 1, with the key .

3.21. REFERENCE OF LINEAR ENCODERS

The Verticot can use two types of probes on the Orbit instrument bus :

- Digital probes of DP type
- Linear encoders of LE type

Because of its working mode, when switched on, a linear encoder gives the value 0, whatever its position. However, an internal function of the probe gives the possibility to reference its measuring range.

So the Verticot has, if necessary, a special function to reference a linear encoder when switching it on.

If this function is selected, the Verticot will display the error 'E 2n' (n=probe nr) when it will be switched on. At that time, the user will have to move in the tip to reference the probe. The probe will display 0 when its tip will be completely out and the maximum of the range when its tip will be in.

The function **Fn40** is used to choose between 'r0': no reference or 'r1': reference.



3.22. LOCKING / UNLOCKING THE KEYBOARD

The use of the advanced functions by means of the keyboard can be protected. This locking can be activated or cancelled (display of 'F.P') by means of the keyboard and by the communication port.

Locking:     Unlocking:    

3.23. GENERAL INITIALISATION

A general initialization of the Verticot can be carried out with the keyboard when switching it on. Use this initialisation very carefully, because it cancels all the internal parameters and set the default parameters (see § 3.24).

Switch on Verticot while pressing the -key, the message 'r' is then displayed during 3 seconds. While 'r' is displayed, press the  -key to start the general initialisation, confirmed by the display of 'rl' (duration: about 3 seconds).

3.24. DEFAULT PARAMETERS

When delivered or after a general initialisation, the Verticot has the following parameters:

- Scale E0 = ± 2 mm; 'direct measurement' mode; 2 inductive and 2 digital probes; no reference of linear encoders
- No storing of lights; 'median' calculation
- Master = 0.0 mm; direct calibration; tolerances of repetition = 5 μ m (0.005 mm)
- No storing of characteristic number
- Upper tolerance = 1.0 mm; lower tolerance = -1.0 mm
- Probe limits: lower = -4.0 mm, upper = 4.0 mm
- Analog outputs: mini = -1 mm, maxi = 1 mm
- Characteristic 1 selected; no automatic change of characteristic
- Probe 1 coefficient of characteristic 1 = 1; all the others set to 0
- Device number = 000; serial speed 9600 baud

4. COMMUNICATION PROTOCOLS

The communication doesn't work during:

- The probes adjustment (see § 2.3)
- The external commands by opto-coupled isolated inputs (see § 6)
- The temporary change of measuring mode (see § 3.13)

4.1. STATUS REGISTERS

The Verticot has 3 status registers internally (on 16 bits), for reading or writing (only with ModBus). These 3 registers describe (R=bit(s) in reading) and activate (W=bit(s) in writing) the different states and working modes of the system.

Register nr 1 'STATUS' :

bits 0,1,2	permanent measurement mode	RW	0 : normal, 1 : average 2 : difference, 3 : maxi, 4 : mini
bit 3	calibration mode	RW	0 : calibration 1: control
bits 4,5,6	part sets	RW	from 0 to 7
bit 7	state upper limit (Led and relay)	R	0 : off 1 : on
bit 8	state lower limit (Led and relay)	R	0 : off 1 : on
bits 9,10,11	measurement scale	RW	from 0 to 6
bits 12 to 15	number of the activated class	R	from 0 to 8

Register nr 2 'STATUS2' :

bits 0 to 4	reserved to 'actions' [if an action is asked, the bits 5 to 15 are ignored]	W	1 : set state 'Stop' 2 : reset state 'Stop' 3 : init. dynamic variables 4 : set relative display 5 : stop relative display 6 : calibration check 7 : cancels access to functions 8 : enables access to functions 9 : calibration command
bits 5,6,7	number of decimals (1 to 5)	RW	
bits 8 to 11	displayed error number	R	from 0 to 15
bit 12	state of system	R	0 : active 1 : state Stop
bit 13	mode 'working indicator lights'	RW	0 : standard 1 : stored
bit 14	calculation 'Average' or 'Median'	RW	0 : median 1 : average
bit 15	checking calibration	R	1 : error E 05

Register nr 3 'STATUS 2' :

bit 0	class display mode	RW	1 : class number
bits 1 to 4	number of classes	RW	see § 3.13
bits 5 to 7	number of inductive probes	RW	see § 3.10
bit 8	reference of linear encoders	RW	0 : no ref. 1 : ref.
bit 9	storing of characteristic	RW	0 : no 1 : yes
bit 10	automatic change of charact.	RW	0 : no 1 : yes

4.2. SIMPLIFIED PROTOCOL

In the following cases, with the device number equal to 0 :

- if the system receives the character ? (code \$3F),
- if the user presses the key  in Stop mode,
- if an impulsion is made on the 'PRINT' entry of the option 'multifunction' or 'relays',

The Verticot will answer with the following message:

V	STATUS1	STATUS2	STATUS3	±00000.00000	CR	LF
---	---------	---------	---------	--------------	----	----

V.....'V'isicote
 STATUS1, STATUS2, STATUS3 3 status register 'in hexa coded ASCII on 4 digits
 value displayed value on 12 digits with sign and
 5 decimals
 CR/LF.....end of message (characters CR and LF)

The 3 registers STATUS1, STATUS2 and STATUS3 are only readable.
 The communication happens in ASCII, at the set-up speed, on 8 bits without parity
 with one 1 stop bit.

4.3. MODBUS (or JBUS) PROTOCOL

4.3.1. GENERALITIES

The Verticot works in slave mode.
 The protocol is used in its binary version.
 The communication works by requests for reading or writing registers (on 16 bits).

The general format of messages is the following :

device number	code function	data	CRC 16 (lsb)	CRC 16 (msb)
------------------	------------------	------	-----------------	-----------------

- number device number (from 1 to 247) 1 byte
- code function code of the asked function 1 byte
- data N bytes
- CRC 2 bytes

Specific use of the ModBus (or Jbus) protocol:

- Readings and writings are only made on 1 register (16 bits) or 2 registers (coded floating point numbers IEEE-754 format)
- Only the following functions are used:
 - Reading of a register or 2 registers (1 float) : code 03
 - Writing of a register or 2 registers (1 float) : code 16 (\$10)

- The most significant byte of the registers and real numbers are transmitted first, except the CRC

Note: in IEEE-754 format, a float is coded, on 32 bits, in the following way :

1 sign bit, exponent on 8 bits, mantissa on 23 bits :

4 bytes: SEEEEEEE EMMMMMMM MMMMMMMM MMMMMMMM

[E = exponent (two's complement with offset 127), S = sign (1 if <0)]

4.3.2. NUMBER OF REGISTERS

1st Status Register	STATUS1	1
2nd Status Register	STATUS2	2
3rd Status Register	STATUS3	3

4.3.3. NUMBER OF REAL VALUES FOR THE SELECTED CHARACTERISTIC

	<i>dec.</i>	<i>hex.</i>
Lower tolerance	10	0A
Upper tolerance	12	0C
Dimension of the master piece	14	0E
Tolerance of repetition of the master piece	16	10
Displayed value	18	12 (<i>read only</i>)
Coefficient probe 1	20	14
Coefficient probe 2	22	16
Coefficient probe 3	24	18
Coefficient probe 4	26	1A
Lower limit probe 1	28	1C
Lower limit probe 2	30	1E
Lower limit probe 3	32	20
Lower limit probe 4	34	22
Upper limit probe 1	36	24
Upper limit probe 2	38	26
Upper limit probe 3	40	28
Upper limit probe 4	42	2A
Lower limit class 1	44	2C
Lower limit class 2	46	2E
Lower limit class 3	48	30
Lower limit class 4	50	32
Lower limit class 5	52	34
Lower limit class 6	54	36
Lower limit class 7	56	38
Lower limit class 8	58	3A
Upper limit class 8	60	3C
Value of 0V (or 4 mA)	62	3E
Value of 10V (or 20 mA)	64	40

4.3.4. READING REQUESTS

Format of incoming questions:

device number	code \$03	number of 1st register	registers 1 or 2	CRC 16 (lsb)	CRC 16 (msb)
1 byte	1 byte	2 bytes	2 bytes	1 byte	1 byte

Format of answers :

device number	code \$03	read bytes 2 or 4	1 or 2 read registers	CRC 16 (lsb)	CRC 16 (msb)
1 byte	1 byte	1 byte	2 or 4 bytes	1 byte	1 byte

Example: To read the measurement displayed by Verticot Nr 001

Message to be send:

01 03 0012 0002 ZZZZ

With: \$01= Verticot number, \$03=reading request, \$0012=N° of the measurement register, \$0002= Nr of byte to be read, \$ZZZZ= CRC16

4.3.5. WRITING REQUESTS

Format of incoming questions:

device number	code \$10	number of 1st register	nb registers : 1 or 2	bytes : 2 or 4	values to write	CRC 16 (lsb)	CRC 16 (msb)
1 byte	1 byte	2 bytes	2 bytes	1 byte	2 or 4 bytes	1 byte	1 byte

Format of answers :

device number	code \$10	number of 1st register	number of registers 1 or 2	CRC 16 (lsb)	CRC 16 (msb)
1 byte	1 byte	2 bytes	2 bytes	1 byte	1 byte

4.3.6. ERROR MESSAGES

The general format of an error message is as follows:

device number	function code + \$80	error code	CRC 16 (lsb)	CRC 16 (msb)
---------------	----------------------	------------	--------------	--------------

The most significant bit of the received function code is set to 1 to indicate the error.

Used error codes:

- \$01 unrecognized function code
- \$02 unknown register number
- \$17 wrong request parameters

5. EXAMPLES OF PROBE COMBINATIONS

5.1. SIMPLE MEASUREMENTS WITH ONE PROBE

In the following examples, the probe combinations are expressed as follows:
 K Cn [K stands for the coefficient applied to probe C number n]

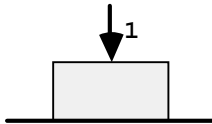

+1 C1
 Thickness

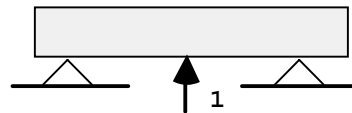

+1 C1
 Flatness

5.2. COMBINED MEASUREMENTS WITH TWO PROBES

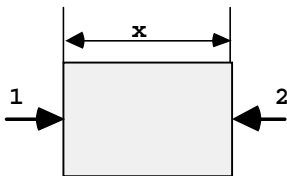

+1 C1 +1 C2
 Thickness or external diameter

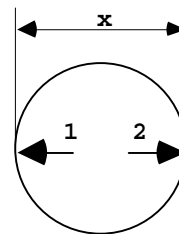

-1 C1 -1 C2
 Width or internal diameter

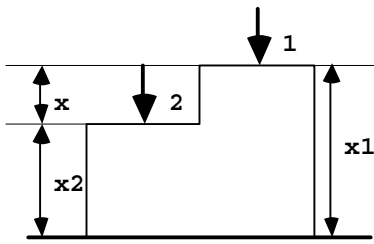

$X_1 = +1 C_1$
 $X_2 = +1 C_2$
 $X = +1 C_1 - 1 C_2$

Thrust

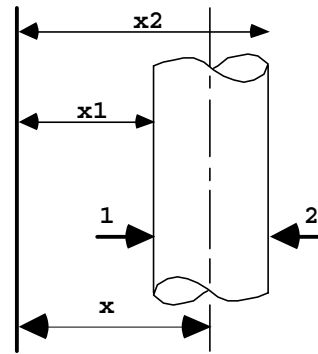

$X_1 = -1 C_1$
 $X_2 = +1 C_2$
 $X = -0.5 C_1 + 0.5 C_2$

Position

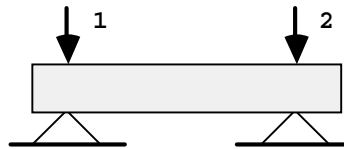

Parallelism

$X = +1 C_1 - 1 C_2$

5.3. MEASUREMENTS WITH THREE PROBES

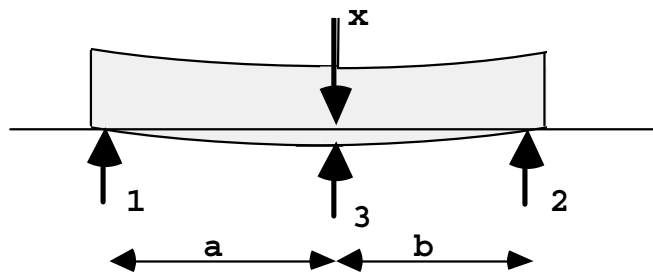

If $a = b$
 $X = +1C_3 - b/(a+b) C_1 - a/(a+b)C_2$
 $X = +1C_3 - 0.5C_1 - 0.5C_2$

Straightness

5.4. MEASUREMENTS WITH FOUR PROBES

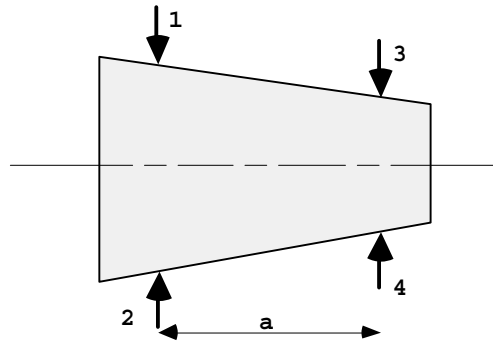

Conicity

$$X = 1 C_1 + 1 C_2 - 1 C_3 - 1 C_4$$

$$dV = 1/a C_1 + 1/a C_2 - 1/a C_3 - 1/a C_4$$

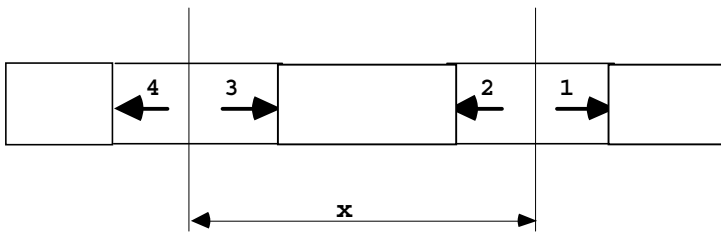

Distance between axes

$$X = -0.5 C_1 + 0.5 C_2 + 0.5 C_3 - 0.5 C_4$$

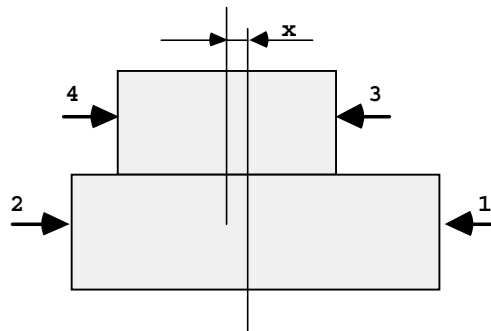

Concentricity

$$X = (0.5 C_1 - 0.5 C_2 - 0.5 C_3 + 0.5 C_4)$$

6. INPUTS / OUTPUTS

The Verticot can be fitted with either one of the two following input / output boards :



- **Relay board ref. OPT-REL** : the contacts of two relays show the position of the measured value by comparison with the tolerances. It also has 4 remote control inputs that automate the measurement.
- **Multi-functional board ref. OPT-MFCT** : it has the functions of the relay board, but also 8 programmable sorting outputs, and two analog outputs (0-10 Volts and 4-20 mA) that are also programmable.

6.1. RELAY BOARD ref. OPT-REL.

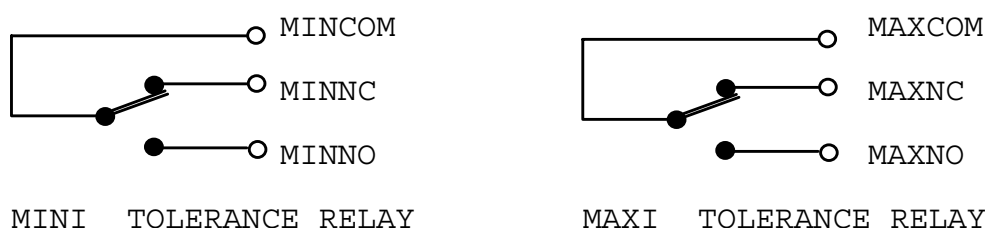
The relay board has two independent and isolated relays indicating the position of the displayed measurement by comparison with the tolerances. Each relay provides a contact that is normally open in case the measurement is within the tolerances (MINNO and MAXNO) and a contact that is normally closed (MINNC and MAXNC). The commons of each relay (MINCOM and MAXCOM) are independent, so that the user is as free as possible.



Four inputs isolated by opto-couplers enable to operate the Verticot by remote control. They are active at the logical level 1 (+12 to + 24 Volts) that must be maintained at 1 for 50 milliseconds minimum. The command is effective when the input comes back to zero, except for the input STOP that stays active as long as the logical level 1 (+12 to + 24 Volts) is maintained.

- **INITDYN** This input controls the initialisation of memories for the dynamic measurement. It must be activated every time the dynamic measurement starts, when the part to be measured is already in place under the probes. This command has the same function as the keyboard key .
- **STOP** This input controls the measurement stop as long as it is maintained at the logical level 1. This command has the same function as the key  of the keyboard.
- **ZERO** This input controls the zero reset of the display. The display then indicates the variations of the measurement in comparison with this origin. This command has the same function as the key  of the keyboard.
- **PRINT** This input controls the sending onto the communication port of the displayed measured value.

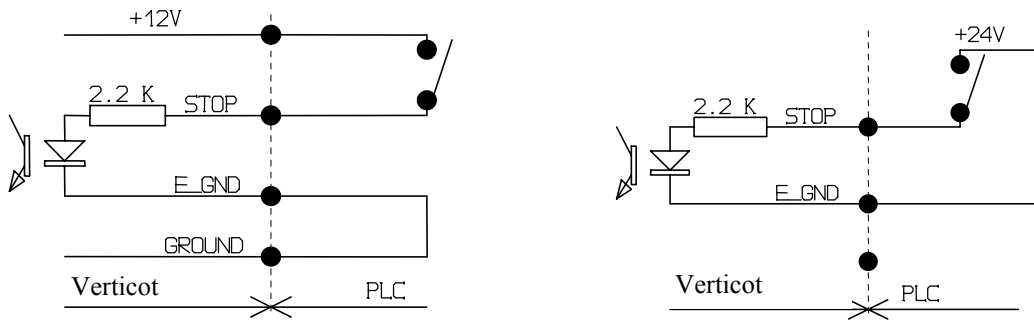

*Examples of command:
with an internal source (not isolated) and with an external source (isolated).*

The Verticot has a memory that can contain 8 data sets corresponding to 8 characteristics. It is possible to select active data (only 1 to 4) with a command applied on the inputs:

a positive pulse (of 50 milliseconds minimum) on input INITDYN, while the input STOP is on, activates (on its falling transition) the reading of the inputs ZERO and PRINT.

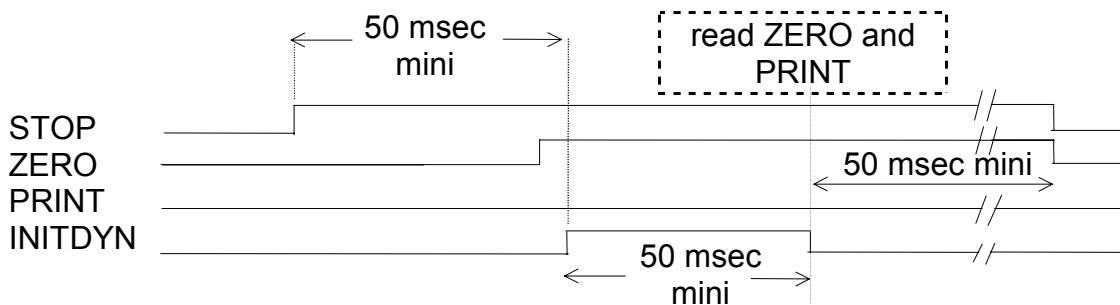

The combination of the ZERO and PRINT inputs determines the data to be activated according to the following table:

PRINT Input	ZERO Input	Selected characteristic
0	0	1
0	1	2
1	0	3
1	1	4

SUB D connector (15 pins) : pin assignment

<i>Pins</i>	<i>Signal</i>	<i>Direction</i>	<i>Description</i>
1	+12 V	output	Power supply to activate the inputs
2	nc	-	Not connected
3	MINNC	-	Mini tolerance relay contact 1A 48V
4	MINCOM	-	Common of mini tolerance contacts
5	MINNO	-	Mini tolerance relay contact 1A 48V
6	E_GND		Power return of the inputs
7	STOP	input	Command for Stop mode
8	PRINT	input	Command for measurement transfer
9	Ground	-	0V / power return 12V
10	nc	-	Not connected
11	MAXNC	-	Maxi tolerance relay contact 1A 48V
12	MAXCOM	-	Common of maxi tolerance contacts
13	MAXNO	-	Maxi tolerance relay contact 1A 48V
14	INIDYN	input	Command for measurement initialisation
15	ZERO	input	Command for display reset to zero

6.2. MULTI-FUNCTIONAL BOARD REF OPT-MFCT

The multi-functional board ref. opt-mfct has the functions of the simple relay board, and also 8 programmable sorting outputs and two analog outputs (0-10 Volts and 4-20 mA) that also are programmable. For the description of common functions, please read the above description of the simple relay board.

The eight sorting outputs are PNP type with an open collector according to the following drawing. They have a commutation power of 20 mA under 48 Volts.

Example of use of a sorting output

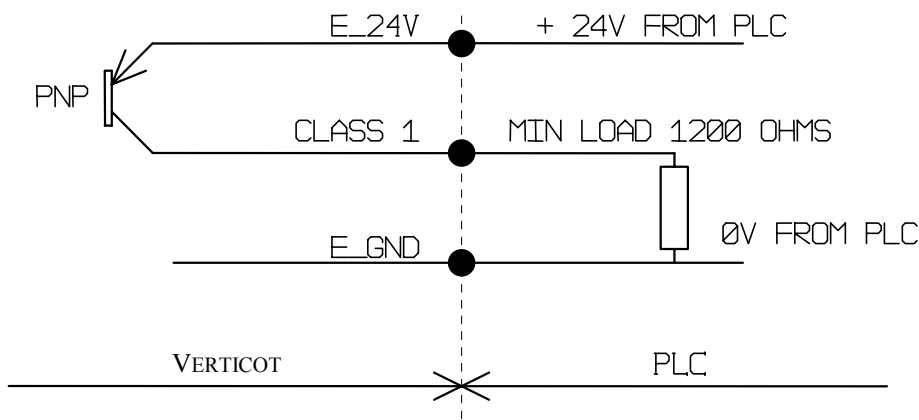

Connector (26 pins) : pin assignment :

<i>Pins</i>	<i>Signal</i>	<i>Direction</i>	<i>Description</i>
1	MINNO	-	Mini tolerance relay contact 1A 48V
2	4-20 OUT	-	Analog output 4-20 mA
3	+12 V	Output	Power supply to activate the inputs
4	Class 1	Output	Class 1 output
5	Class 3	Output	Class 3 output
6	Class 5	Output	Class 5 output
7	Class 7	Output	Class 7 output
8	E_GND		Power return of the inputs
9	E_24V	Input	24 V external power supply for sort
10	MINCOM	-	Common of mini tolerance contacts
11	4 -20 RET	-	Analog output return 4-20 mA (-12V)
12	0 -10 V		Analog output 0 -10 V
13	Ground	-	Earth / power return 12V
14	Class 2	Output	Class 2 output
15	Class 4	Output	Class 4 output
16	Class 6	Output	Class 6 output
17	Class 8	Output	Class 8 output
18	E_24V	Input	External power supply 24 V for sort
19	MINNC	-	Mini tolerance relay contact 1A 48V
20	MAXNO	-	Maxi tolerance relay contact 1A 48V
21	MAXCOM	-	Common of maxi tolerance contacts
22	MAXNC	-	Maxi tolerance relay contact 1A 48V
23	INIDYN	Input	Command for measurement initialization
24	STOP	Input	Command for measurement stop
25	ZERO	Input	Command for display reset to zero
26	PRINT	Input	Command for measurement transfer

The analogue output type "current loop 4/20 mA" is used to transmit an analogue signal on a long distance. The loop current takes the following values:

When display = mini threshold; current = 4 mA

When display = maxi threshold; current = 20 mA

The maximum admitted load resistance is 500 Ω , connection cables included.
The 4-20 mA return is connected to -12V in comparison with the ground of the device.

7. ERROR MESSAGES

Every time the Verticot detects an error, it displays an error message as long as the error stays. The only way to go back to a normal situation is to cancel the error. The error messages are displayed as follows: *E xx*, where *xx* represents the error number.

Message	Cause	Action
E01	Exceeded range on probe 1	- come back to the measuring range of the probe - change the measuring range of the probe if it is incorrect.
E02	Exceeded range on probe 2	idem
E03	Exceeded range on probe 3	idem
E04	Exceeded range on probe 4	idem
E05	Exceeded tolerance of repetition during the control on the master piece	- measure the master piece again - make another calibration - change the tolerance of repetition.
E06	Time exceeding in dynamic measurement (in average measurement mode)	press the key  to reset to zero the maximum and minimum memories used to measure the shape faults.
E07 to E10	Exceeded AD converter for probes 1 (E07) to 4 (E10)	come back in measuring range of converter (± 2000 points)
E11 to E14	Digital probes 1 (E11) to 4 (E14) don't answer	- check the probes connections (Orbit bus) - identify the digital probe
E21 to E24	Linear encoders 1 (E21) to 4 (E24) must be referenced	move in the probe tip

8. APPENDIXES

8.1. APPENDIX A

ONE YEAR LIMITED WARRANTY ON VERTICOT PARTS

MANUFACTURER'S RESPONSIBILITY

VERTICOT - PRODUCTS HARDWARE AND LABOUR PARTS. From a period of one year from the effective warranty date, the manufacturer will pay for service labour and replacement parts. Replacement parts may be new or manufactured at the option of the manufacturer and are warranted for the remaining portion of the original warranty period.

FIRST END-USER COVERAGE. This warranty applies only to the first end-user of the product and is not assignable to any other subsequent purchaser or user.

NOT COVERED. Any accessory or expansion item not included in the original factory packaging for the product is not covered.

Costs of installation or adjustment or damage resulting from causes beyond the control of the manufacturer, including acts of God, misuse, neglect, accident damage occurring in shipment or from improper installation, operation or application; or damage resulting from use of products, components, accessories or expansion items not supplied by the manufacturer are not covered. It also does not cover products, which have been altered in any way without the written approval of the manufacturer including electrical or mechanical alteration, removal of serial numbers or the manufacturer trademarks or other identification.

THE SOLE REMEDY UNDER THIS WARRANTY SHALL BE REPAIR OR REPLACEMENT OF DEFECTIVE PARTS AS PROVIDED ABOVE. UNDER NO CIRCUMSTANCES SHALL THE MANUFACTURER BE LIABLE IN ANY WAY TO THE USER FOR INDIRECT, SPECIAL, INCIDENTAL OR CONSEQUENTIAL DAMAGES, INCLUDING BUT NOT LIMITED TO, ANY LOSS OF DATA, BUSINESS OR PROFITS, WHETHER OR NOT FORESEEABLE AND WHETHER OR NOT BASED ON BREACH OF WARRANTY.

THE PRESENT WRITTEN WARRANTY IS IN LIEU OF ALL OTHER WARRANTIES, EXPRESSED OR IMPLIED, INCLUDING BUT NOT LIMITED TO ANY WARRANTY OF MERCHANTABILITY OR FITNESS FOR A PARTICULAR PURPOSE, AND ALL WARRANTIES ARE EXPRESSLY EXCLUDED AND NEGATED.

OWNER'S RESPONSIBILITY

OPERATING MANUAL AND OTHER DOCUMENTATION. Please read your operating manual and other documentation very carefully so that you have a good understanding of how it works. It may be possible to avoid unnecessary service work, which may not be covered by this warranty.

AFTER SALES SERVICE. If the product is defective, take it to an authorised dealer.

8.2. APPENDIX B

SAFETY NOTICES

CAUTION: To reduce the risk of electric shock which could cause personal injury, follow all safety notices. The symbols shown are used in your documentation and on your equipment to indicate safety hazards.



This device corresponds to the EN61010-1 safety standard and EN55022 class B, CEI 801-2 (level II), CEI 801-3 (level III), CEI 801-4 (level IV) electromagnetic compatibility.

The user is cautioned that changes or modifications not expressly approved by the party responsible for compliance could void the user's authority to operate the equipment.